

## RESEARCH ARTICLE

# A Model Approach for Assessing the Benefits of HPV Testing against Cytology in Screening for Cervical Cancer Precursors in Thailand

Tanitra Tantitamit<sup>1\*</sup>, Wichai Termrungruenglert<sup>2</sup>, Nipon Khemapech<sup>2</sup>, Piyalamporn Havanond<sup>2</sup>

### Abstract

**Objective:** The aim of this study was to compare the efficacy of HPV 16/18 genotyping test, high risk HPV DNA testing, alone and in conjunction with the liquid-based cytology method in screening for cervical cancer precursors. **Methods:** A Markov model was used to describe the course of the cases of CIN2+ that had been detected over a 35 year period. Screening programs started at age 30 and were performed at an interval of once every five years. The model compared three strategies of HPV 16/18 genotyping with reflex cytology triage, high-risk HPV testing alone with referral to colposcopy and cytology-based screening with referral to colposcopy. We assumed the rate of patients lost to follow-up for those referred to colposcopy would be 0%. The clinical parameters were estimated using the data from a study conducted by the Thailand National Cancer Institute. **Result:** Of the three screening strategies evaluated, the high risk HPV DNA testing alone was the most effective for detecting CIN2+ over the 35 year study period. It detected 143 and 510 cases per 100,000 women more than the HPV 16/18 genotyping test and cytology-based strategy, respectively. The HPV genotyping test detected 368 cases per 100,000 women more than the cytology-based approach. In addition, when viewed with five year intervals, there were missed cases totaling approximately half of the detected cases screened by the cytology strategy and 10% of cases detected with screening by the HPV genotyping test. **Conclusion:** This study strongly indicates that HPV/DNA testing is preferable to cytology-based screening for cervical cancer precursors. However, the balance between the benefits, burdens and cost of each screening program should be considered.

**Keywords:** Cervical cancer- Screening- Human papillomavirus testing- Liquid based cytology- Mathematical Models

*Asian Pac J Cancer Prev*, **18** (5), 1271-1275

### Introduction

Cervical cancer is the second most common cancer, globally. In 2012, more than 8,000 women per 100,000 here in Thailand were diagnosed with cervical cancer and more than half of these cases proved fatal (Bruni et al., 2015). Because of it develops over time, it is one of the preventable types of cancer. The optimal screening test and management for precancerous lesions can reduce morbidity and mortality. Papnicolaou cytology (PAP smear) has been proven to be an effective screening method. It results in the reduction of both the incidence and subsequent mortality. In 2005, the National Health Security Office and Ministry of Public Health (MoPH) of Thailand initiated a comprehensive cervical cancer screening program. Thai women at the ages of 30-60 years are encouraged to undergo a cytology based screening program once every 5 years. In 2006, the program was expanded to include a visual inspection with acetic acid

(VIA) screening in certain provinces. National targets for the percentage of women aged 30-60 years who had been screened for cervical cancer once in the previous 5 years were 80% in 2013. The results of the 2010 MoPH survey have shown that 67.4% of women had been screened within the past 5 years (Joseph et al., 2015). Although it appears close to reaching stated targets, there was low screening in some subpopulations. Furthermore, almost half of the women with abnormal tests were lost to follow up. The primary reason that was given for non-attendance was lack of communication. The patient did not receive written information in the form of a letter and those who received their letters did not understand the information provided (Sriamporn et al., 2006). These are limitations of the cytology based screening program. The program requires multiple follow up visits due to its low sensitivity and the high variability of results between laboratories. This program also requires an ample amount of trained cytopathologists and efficient transport and tracking

<sup>1</sup>Department of Obstetrics and Gynecology, Faculty of Medicine, HRH Princess Maha Chakri Sirindhorn Medical Center (MSMC), Srinakharinwirot University, Nakornnayok, <sup>2</sup>Department of Obstetrics and Gynecology, Faculty of Medicine, King Chulalongkorn Memorial Hospital, Chulalongkorn University, Bangkok, Thailand. \*For Correspondence: [tanitra@gmail.com](mailto:tanitra@gmail.com)

systems.

To improve the effectiveness of this screening program, an appropriate strategy should be developed that not only increases the coverage rates but also increases the detection rates of the disease earlier in the progression. Persistent high risk HPV infection is a cause of cervical cancer. This leads to consideration in determining HR-HPV testing as an alternative screening method. HPV testing has greater sensitivity and fewer false negatives than has been seen in cytology. There is evidence from several large clinical trials that have proved that the benefits of primary screening for HPV can outweigh the potential risks and is superior to standard cytology (Campos et al., 2015; Huh et al., 2015; Jin et al., 2016; Wright et al., 2015). Several countries have now adopted primary screening for HPV in their national screening programs. This study need to evaluate the efficacy of HPV testing as an effective screening test in Thailand.

## Materials and Methods

**Objective** The objective of this study is to compare the efficacy of HPV genotyping test, HR-HPV DNA testing and liquid based cytology methods for the detection of high grade cervical disease.

**Study population** The model evaluates the outcomes of a hypothetical cohort of 100,000 healthy women 30 to 65 years of age.

**Comparison of screening strategies** The three primary cervical screening strategies were compared (Figures 1-3 for detailed algorithms).

1. HPV 16/18 genotyping and reflex liquid based cytology

This strategy utilizes HPV testing with genotyping as the primary screening modality. Women who are negative return for routine screening in 5 years. Women who are HPV 16/18 positive are referred for immediate colposcopy. Women positive for other 12 HR-HPV have cytological testing. Cytology with resulting atypical cells of undetermined significance (ASCUS) or worse lead to immediate colposcopy. Women with normal results obtained from cytology are told to return for follow up HPV testing in 12 months.

2. HR-HPV testing alone followed by a referral for a colposcopy for hr-HPV positive woman.

3. Cytology based screening followed by a referral for a colposcopy for PAP positive women.

Routine screening is preformed once every 5 years and this is based on clinical guidelines from The National cancer institute of Thailand. Diagnostic conization is considered in strategies 1 and 3 if the results show any discrepancy in the cervical cytology or the colposcopic biopsy. We assume that the loss to follow-up rate for those referred to colposcopy will be at 0%.

### Markov Model structure

We developed a mutually exclusive, state transition testing, Markov chain (Doibilet et al,1985; Sonnerber and Back, 1993) to portray the screening management for the detection of CIN2+ cases using Excel spreadsheet version 15.17 (151206), 2015, Microsoft.

The Natural history model served as the framework within which the effects of each screening strategy were applied and the outcomes compared. Women transitioned annually across 5 possible states; 1) No high risk HPV infection, 2) High Risk HPV infection, 3) Cytology abnormality, 4) CIN2 or 5) condition worsening and fatal. Regression from the CIN 2 to a no CIN state had not occurred. We have modeled health states for pre-cancerous lesions arising from HPV infections. We have not reported on the progression from CIN2 to cancer.

Age-adjusted annual probabilities of death for women without cervical cancer were derived from the general population estimates as reported in the Estimated Generation Life Tables for Thailand of Five-Year Birth Cohorts, 1900-2000 (Prasatkun and Rakchanyaban, 2002).

### Model inputs

The probabilities for the prevalence of women who are positive for HPV 16/18, women positive for HR-HPV and women cytology positive are a requirement for the model. All of these were taken from the data of National Cancer Institute of Thailand which had enrolled 5056 Thai women, 30-65 years of age, who were undergoing cervical cancer screening. It is the largest trial done to evaluate HPV testing in Thailand. (National Cancer Institute of Thailand, unpublished data 2016)

The incidence of HPV16/18 positive women was 9.3%. The incidence of HR-HPV positive women was approximately 3.5%. The incidence of cytology positive women was 1.5%. The model outcome is the detection rate of CIN2+ for women over 35 years of age and a reduction allowance at an annual rate of 3% (Table1).

### Model outcome

The model's outcome or dependent variable is the cumulative detection rates of CIN2, CIN3 and cervical cancer cases that had been calculated over a period of 35 years. An annual reduction of 3% is assumed by the Markov model.

### Sensitivity analysis

A one-way sensitivity analysis undertaken to assess the impact of the parameter uncertainty on the model's results followed a standard Monte Carlo approach that had been based on 10,000 randomly generated simulations of parameter values.

## Results

Throughout the 35 years of cervical screening, the detection rate of CIN2+ using the HPV 16/18 genotype, HR-HPV testing and Liquid base cytology were 1,389, 1,520 and 1,013 cases per 100,000 women, respectively (Table 2). The Model prediction indicates that high risk HPV-DNA testing alone was the most effective strategy. Whereas, it has been found that the least effective strategy is the cytology based screening method and this is currently the most common practice utilized in Thailand.

The graph in Figure 4 shows the comparisons of the detection rates of all three strategies over the 35 year study period. HR-HPV testing alone detected 143 and 510 more

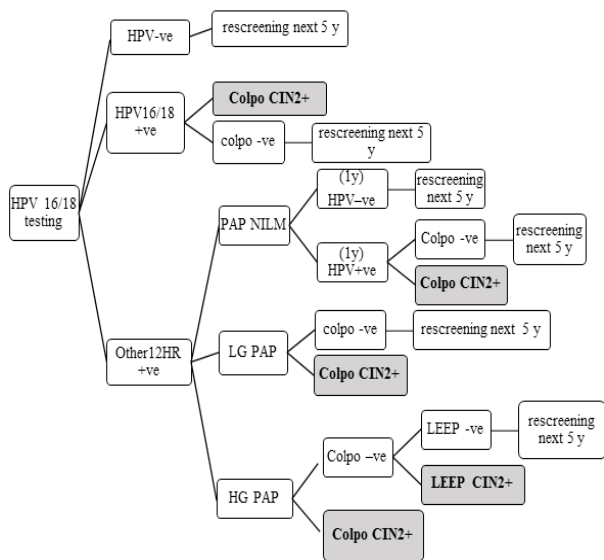

Figure 1. HPV 16/18 Genotyping and Reflex Liquid Based Cytology

cases per 100,000 women than the HPV genotyping test and the cytology-based strategy, respectively. Comparing the HPV genotyping test and cytology-based testing, the HPV genotyping test detected 368 more cases per 100,000 women than did the cytology-based test. In addition, about half of detected cases were missed in screening by the cytology strategy and 10% of the detected cases screened by the HPV genotyping test in comparison to HPV testing alone when the women were tested at the 5 year intervals.

A probabilistic sensitivity analysis (PSA) was conducted to determine how differences in the prevalence

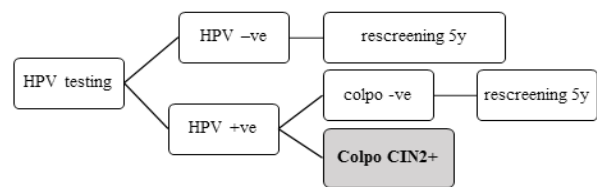

Figure 2. Using hr-HPV Testing alone Every 5 Years Followed by Colposcopy for Women with hr-HPV Positive Results

of HPV infection and women with positive cytology impact the detection rates of CIN2+. The results suggest that if the incidence of HPV infection increases at least 3 times, HPV genotyping might be the most effective strategy and have also detected approximately 1,200 cases per 100,000 more than in strategy 2. The liquid based cytology method would be more effective if the sensitivity of the cytology was increased (Table3).

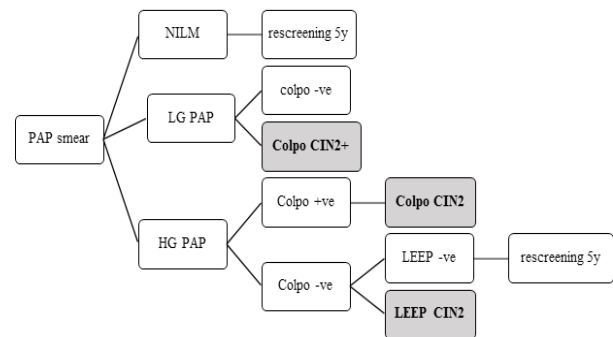

Figure 3. Screening by LBC Alone, with Referral of All Women with ASCUS or Worse to Colposcopy

Table 1. Epidemiological Parameters and Ranges Used in the Sensitivity Analysis

Prevalence	Rate	Range	Ref
<b>STRATEGY 1</b>			
HPV16/18	0.0093	0.0084 - 0.0279	NCI
Other 12HR positive	0.025	0.0025 - 0.075	NCI
HPV16/18+ → Colpo CIN2 +	0.191		NCI
Other 12 HR +ve → LG cyto	0.296		NCI
Other 12 HR +ve → LG cyto → Colpo CIN2	0.078		NCI
Other 12 HR +ve → NILM → (wait 1y) HPV+ve	0.25		†
Other 12 HR +ve → NILM → (wait 1y) HPV+ve → Colpo CIN2+	0.2		†
Other 12 HR +ve → HG cyto	0.148		NCI
Other 12 HR +ve → HG cyto → Colpo -ve → Conization CIN2+	0.06		NCI
Other 12 HR +ve → HG cyto → Colpo CIN2+	0.15		NCI
<b>STRATEGY 2</b>			
HR-HPV +ve	0.0346	0.0311 - 0.1038	NCI
HR-HPV +ve → Colpo CIN2+	0.114		NCI
<b>STRATEGY 3</b>			
LG cyto +ve	0.008	0.0072 - 0.024	NCI
LG cyto +ve → Colpo CIN2+	0.11		NCI
HG cyto +ve	0.0067	0.00603 - 0.201	NCI
HG cyto → Colpo CIN2+	0.2		NCI
HG cyto → Colpo -ve → Conization CIN2+	0.074		NCI

\*, Reference form Expert's opinion; NCI, National Cancer Institute of Thailand

Table 2. Outcomes of the Three Cervical Screening Strategies

Strategy		Detection rate (per 100,000 women)
1	HPV16/18	1,389.98
2	HR-HPV testing	1,520.10
3	Cytology LBC	1,013.94

### Discussion

In this study, HPV based testing is superior than the cytology based strategy for detecting CIN2+ cases. The cytology method has the highest numbers of missed cases. This is in line with several studies that recommend HPV testing to replace cytology as the primary screening method (Campos et al., 2015; Huh et al., 2015; Jin et al., 2016; Kitchener et al., 2014; Wright et al., 2015). In a comparison of HPV genotyping and HPV testing alone, a study has shown that HPV testing alone is more effective

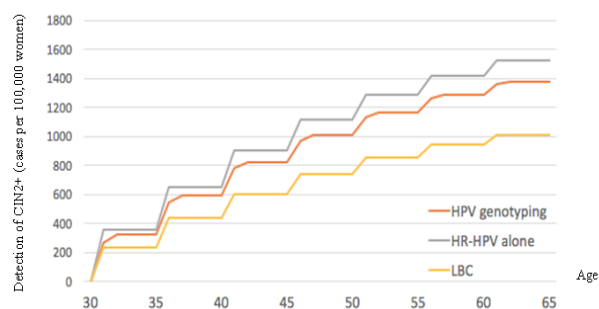

Figure 4. Comparison the Detection Rate of CIN2+ Cases per 100,000 Women among the Three Strategies

than HPV genotyping. Whereas, most previous studies have revealed HPV genotyping as the most effective strategy (Wright et al., 2016; Beal et al., 2014; Huh et al., 2015). This may be explained by many reasons. First, we used the incidence and genotypic distribution of HPV in Thai women which contrasts most studies that have been

Table 3. Probabilistic Sensitivity Analysis of the Three Strategies

Plausible prevalence of		Strategy	Detected cases (per 100,000 women)
HPV 16/18 positive women in strategy 1	0.0084	2	1,520
		1	1,325
		3	1,013
	0.0279	2	1,520
		1	2,690
		3	1,013
Other 12 HR-HPV positive women in strategy 1	0.0225	2	1,520
		1	1,311
		3	1,013
	0.075	2	1,520
		3	1,013
		1	2,726
HR-HPV positive women in strategy 2	0.03114	2	1,375
		1	1,381
		3	1,013
	0.1038	2	4,351
		1	1,381
		3	1,013
Low grade cytology positive women	0.0072	2	1,524
		1	1,381
		3	979
	0.024	2	1,524
		1	1,318
		3	1,691
High grade cytology positive women	0.00603	2	1,524
		3	947.7
		1	1,381
	0.0201	2	1,524
		1	1,381
		3	2,319



done in Western countries (Wright et al., 2012; Husain et al., 2015; Kietpeerakool et al., 2015; Kantathavorn et al., 2015). In addition, each step that followed the first screening was different among several studies. Also, the population of the NCI study that has been used as clinical data was small. This may reflect on the impact of the rate of HPV infection and women who were cytology positive.

This is the first study to assess the efficacy of the HPV-based method as a primary screening cervical cancer precursor in Thailand. We used model analysis and conducted sensitivity analysis to represent the actual situations. Furthermore, base case values used in the model were based on the largest amount of and latest data from Thailand. However, there are a few limitations to this study. First, the efficacy we used for comparison is only an intermediate outcome of cervical cancer. Second, clinical input data obtained from a single institute and does not represent the entire population in Thailand. Last, excluding the non compliant cases at follow up, could have possibly over estimated the case numbers.

For a more accurate prediction of the most effective strategy, future studies should be based on the data from multi-centers in several regions of Thailand. Long term clinical outcomes such as lifetime cervical cancer risks or the impact of the women's quality of life should be assessed. It would be helpful if either VIA and Care-HPV tests can be used as comparative algorithms, especially in low resource settings. In policy making plans, economic analysis studies should be evaluated to identify the best strategy.

In conclusion, this study strongly supports the HPV DNA testing as a preferable option to cytology-based screening for detecting cervical cancer. However, the balance between the benefits, burdens and cost of each screening program should be considered.

#### Statement conflict of Interest

None.

#### Funding Statement

None.

#### Presentation

Data from this study has been presented at the EUROGIN 2016th congress in Salzburg, Austria, Jun 15-18, 2016

### Acknowledgements

This research was partially supported by Dr. Suleeporn Sangrajrang and her colleagues of the Health System Development National Cancer Institute

### References

Beal CM, Salmeron J, Flores YN, et al (2014). Cost analysis of different cervical cancer screening strategies in Mexico. *Salud Publica Mex*, **56**, 429-501.

Bruni L, Barrionuevo-Rosas L, Albero G, et al (2015). ICO information centre on HPV and cancer (HPV information Centre). Human papillomavirus and related diseases in

Thailand. Summary report, pp12-23.

Campos NG, Maza M, Alfaro K, et al (2015). The comparative and cost-effectiveness of HPV-based cervical cancer screening algorithms in El Salvador. *Int J Cancer*, **137**, 893-902.

Doubilet P, Begg CB, Weinstein MC, et al (1985). Probabilistic sensitivity analysis using Monte Carlo simulation: a practical approach. *Med Decis Making*, **5**, 157-7

Huh WK, Ault KA, Chelmon D, et al (2015). Use of primary high-risk human papillomavirus testing for cervical cancer screening: interim clinical guidance. *Obstet Gynecol*, **125**, 330-7.

Husain RS, Ramakrishnan V (2015). Global variation of human papillomavirus genotypes and selected genes involved in cervical malignancies. *Ann Glob Health*, **81**, 675-83.

Huh WK, Williams E, Huang J, et al (2015). Cost effectiveness of human papillomavirus-16/18 genotyping in cervical cancer screening. *Appl Health Econ Health Policy*, **13**, 95-107.

Jin XW, Lipold L, Foucher J, et al (2016). Cost-effectiveness of primary HPV testing, cytology and co-testing as cervical cancer screening for women above age 30 years. *J Gen Intern Med*, **31**, 1338-44

Joseph R, Manosontorn S, Petcharoen N, et al (2015). Assessing cervical cancer screening coverage using a population-based behavioral risk factor survey--Thailand, 2010. *J Womens Health (Larchmt)*, **24**, 966-8.

Kantathavorn N, Mahidol C, Sritana N, et al (2015). Genotypic distribution of human papillomavirus (HPV) and cervical cytology findings in 5906 Thai women undergoing cervical cancer screening programs. *Infect Agent Cancer*, **10**, 7.

Kietpeerakool C, Kleebkao P, Srisomboon J (2015). Human papillomavirus genotype distribution among Thai women with high-grade cervical intraepithelial lesions and invasive cervical cancer: a literature review. *Asian Pac J Cancer Prev*, **16**, 5153-8.

Kitchener HC, Canfell K, Gilham C, et al (2014). The clinical effectiveness and cost-effectiveness of primary human papillomavirus cervical screening in England: extended follow-up of the ARTISTIC randomized trial cohort through three screening rounds. *Health Technol Assess*, **18**, 1-196.

Prasatkun P, Rakchanyaban U (2002). Estimated generation life tables for Thailand of five-year birth cohorts: 1900-2000. Institute for population and social research, Mahidol University.

Siebers AG, Klinkhamer PJ, Grefte JM, et al (2009). Comparison of liquid-based cytology with conventional cytology for detection of cervical cancer precursors: a randomized controlled trial. *JAMA*, **302**, 1757-64.

Sonnenber FA, Beck JR (1993). Markov models in medical decision making: a practical guide. *Med Decis Making*, **13**, 322-8

Sriamporn S, Khuhaprema T, Parkin M (2006). Cervical cancer screening in Thailand: an overview. *J Med Screen*, **13**, 39-43.

Wright TC, Stoler MH, Behrens CM, et al (2012). The ATHENA human papillomavirus study: design, methods, and baseline results. *Am J Obstet Gynecol*, **206**, 1-11.

Wright TC, Stoler MH, Behrens CM, et al (2015). Primary cervical cancer screening with human papillomavirus: end of study results from the ATHENA study using HPV as the first-line screening test. *Gynecol Oncol*, **136**, 189-97.